



AMORTIGUADORES

AMORTISSEURS

SHOCK ABSORBERS

ALKO

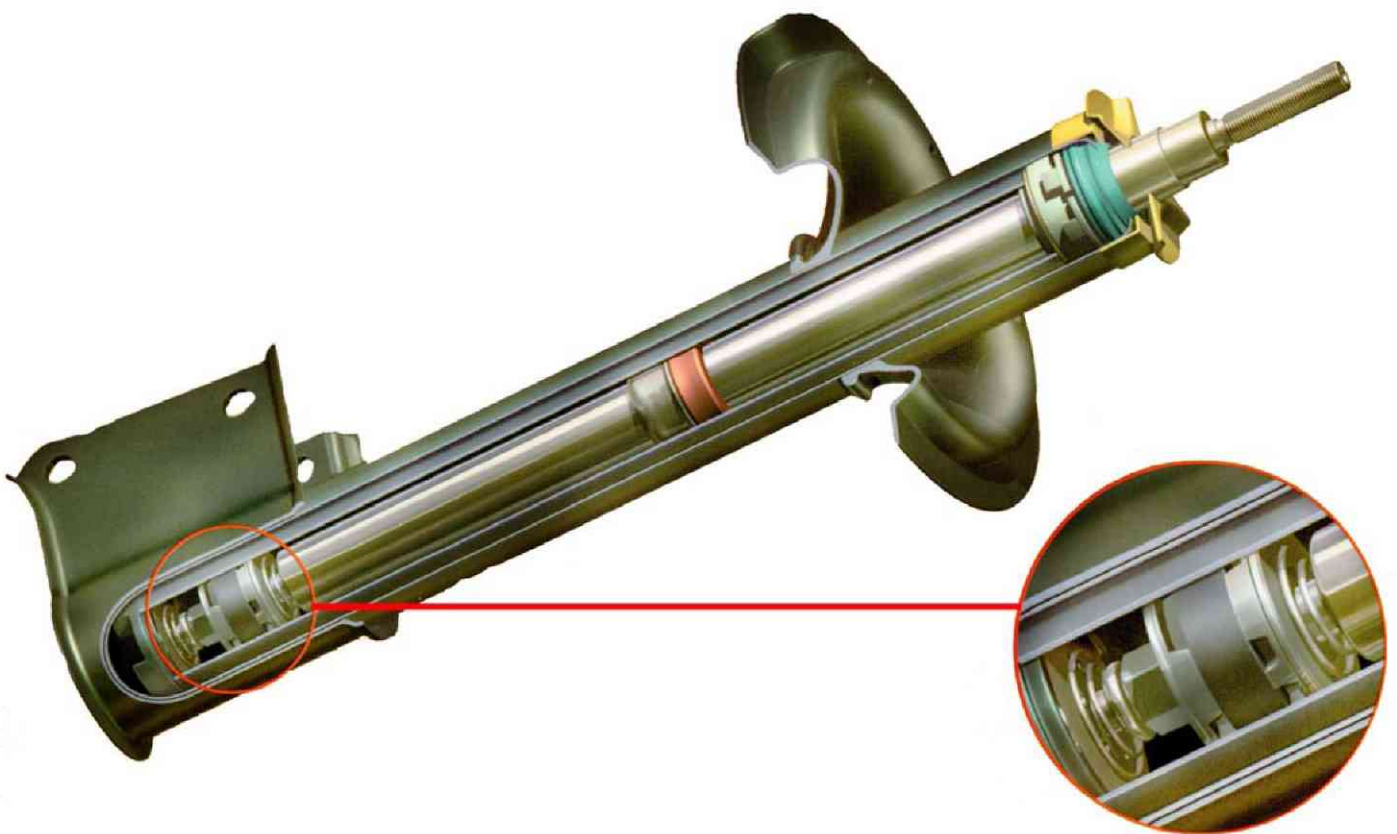

SIMBOLOS Y LEYENDA / SYMBOLES ET LEGENDE / SYMBOLS AND EXPLANATION

	Kits de protección para amortiguadores <i>Kits de protection pour AMORTISSEURS</i> Shock absorber protection kits		Montaje especial <i>Fixation spéciale</i> Special mounting		Columna completa <i>Jambe de force</i> Strut
	Cartucho <i>Fusée</i> Cartridge		Suspensión regulable electronicamente <i>Suspension électronique réglable</i> Electronically adjustable suspension		Superior e inferior con aros <i>Fixation supérieure</i> Top and bottom eye mounting
	Muelle helicoidal <i>Ressort hélicoïdal</i> Coil spring		Espiga superior, aro inferior <i>Fixation supérieure oeil</i> Top stem, bottom eye mounting		Suspensión neumática <i>Suspension pneumatique</i> Air suspension
	Espiga superior e inferior <i>Fixation supérieure et inférieure tige</i> Top and bottom pin mounting		Muelle de láminas <i>Ressort à lames</i> Leaf spring		Superior aro, inferior espiga <i>Fixation supérieure oeil, inférieure tige</i> Top eye, bottom pin mounting
	Fijaciones <i>Fixation</i> Mounting		Topes de suspensión <i>Roulements de suspension</i> Suspension strut bearings		Vehículos equipados con sistema de regulación de nivel <i>Véhicules équipés d'un système de réglage de niveau</i> Vehicles with self-levelling suspension

Alle..... Todos.....	Tous.....	All
Ch.n... Chasis número.....	Chassis numéro.....	Chassis number
D..... Derecho.....	Droit.....	Right
Ex..... Excluído.....	Sauf.....	Excluding
HD..... Suspensión reforzada.....	Suspension renforcée.....	Heavy duty
I..... Izquierdo.....	Gauche.....	Left
*..... El cartucho es solamente utilizable en las columnas roscadas; en caso contrario reemplazar por la columna completa	Cartouche utilisable que pour jambes de force exécution a vis autrement remplacer par la jambe de force complète	Insert fit only non sealed strut; otherwise replace by complete strut



RENAULT (E)



**HYDRO
TECH**

**TOP
ROAD
GAS**



**HYDRO
TECH**

**TOP
ROAD
GAS**



R 4 (R 112_), R 6 (R 118_)

R 4, R 4 S	01.61 ⇌ 08.68		AM.1024					AM.1025	
R 4, R 4 F, R 4 F 6	09.68 ⇨		AM.1026	AM1026G				AM.1025	
R 6	09.68 ⇨		AM.1026	AM1026G				AM.1025	

R 5 (R 122_, R 139_, R 238_), R 7

R 5 Exc. Copa	01.72 ⇌ 12.85		AM.1026	AM1026G				AM.1027	AM.1027G
R 7	01.72 ⇌ 12.85		AM.1026	AM1026G				AM.1027	AM.1027G

R 12 (R 117_)

	⇨ 04.72		AM.2056					AM.1226	
	05.72 ⇨		AM.2058					AM.1226	

R 14 (R 121_)

R 14 Ch. 0345946 ⇨ 0007533	01.76 ⇌ 12.78		AM.8926			S009		AM.1027	AM.1027G
R 14 Ch. 0345947 ⇨ 0007534	01.78 ⇌ 12.83		AM.8324			S022		AM.1027	AM.1027G

R 18 (R 134_, R 135_)

Gasoline			AM.2253					AM.1254	
Diesel	⇨ 05.83		AM.2428					AM.1254	
Diesel, Turbo	06.83 ⇨		AM.2516					AM.1254	

RENAULT (F)

CLIO I (B/C57_, 5/357_)

1.1 1.2 1.4 Exc. 1.4 Aut.	01.90 ⇌ 07.97		AM.3847 ⁸ AM.3855 ⁸	AM.3855G ⁸	L011			AM.1859	AM.1859G
1.4 	01.90 ⇌ 07.97		AM.3847 ⁸ AM.3855 ⁸	AM.3855G ⁸	L011			AM.1859	AM.1859G
1.7 1.8 1.9 D Exc. 1.8 16v Exc. 1.8 RSi	01.90 ⇌ 07.97		AM.3855 ⁸	AM.3855G ⁸	L011			AM.1859	AM.1859G

... RENAULT (F)

HYDRO TECH
TOP ROAD GAS

HYDRO TECH
TOP ROAD GAS

... CLIO I (B/C57_, 5/357_)

1.8 RSi	01.90 ⇄ 07.97								AM.1859G
1.2 1.4	08.97 ⇄ 09.98		AM.3089 ⁸ AM.3847 ⁸		L011			AM.1859	AM.1859G
1.8 1.9 D Exc. 1.8 RSi	08.97 ⇄ 09.98		AM.3089 ⁸ AM.3847 ⁸		L011			AM.1859	AM.1859G
1.8 RSi	08.97 ⇄ 09.98								AM.1859G

CLIO II (B/C/B0/1_)

1.1, 1.2, 1.2 16v	09.98 ⇄		AM. 3097		L011			AM.1174	AM.1174G
1.4, 1.4 16v 1.6, 1.6 16v 1.9 D, 1.9 dTi, 1.5 dCi Exc. 1.6 Sport 16v Exc. 2.0 Sport 16v Exc. Sport V6	09.98 ⇄		AM. 3098	AM.3098G	L011			AM.1174	AM.1174G
1.4, 1.6 1.9 dTc Exc. 2.0 Sport 16v Exc. Sport V6	09.98 ⇄			AM.3098G	L011				AM.1174G

CLIO II, SYMBOL, THALIA (B/C/B0/1_)

1.4 8v 	09.98 ⇄		AM.3202*					AM.1174	AM.1174G
1.4 16v 	09.98 ⇄		AM. 3098	AM.3098G	L011			AM.1174	AM.1174G
1.5 dCi 	09.98 ⇄		AM. 3097		L011			AM.1174	AM.1174G

ESPACE I (J/S 11_)

J 112 Petrol Ch. ⇄ T 005812	07.84 ⇄ 11.84								AM.1330G
J 112 Petrol Ch. T 005813 ⇄ T 036434	12.84 ⇄ 12.87								AM.1330G
J 115 Diesel Ch. ⇄ T 020896	12.84 ⇄ 12.87								AM.1330G
J 117 Petrol Injection Ch. ⇄ T 003258	12.84 ⇄ 12.87								AM.1330G
S 112 Petrol Ch. ⇄ T 000620	12.84 ⇄ 12.87								AM.1330G
S 115 Diesel Ch. ⇄ T 000841	12.84 ⇄ 12.87								AM.1330G



... RENAULT (F)



**HYDRO
TECH**

**TOP
ROAD
GAS**



**HYDRO
TECH**

**TOP
ROAD
GAS**



... ESPACE I (J/S 11_)

J 112 Petrol Ch. K 000001 I-> Ch. T 036435 I->	01.88 12.91		AM.2255G				AM.1330G
J 115 Diesel Ch. T 020897 I->	01.88 12.91		AM.2255G				AM.1330G
J 116 Petrol Injection Ch. K 000001 I-> Ch. T 000001 I->	01.88 12.91		AM.2255G				AM.1330G
J 117 Petrol Injection Ch. T 003259 I->	01.88 12.91		AM.2255G				AM.1330G
S 112 Petrol Ch. T 000621 I->	01.88 12.91		AM.2255G				AM.1330G
S 115 Diesel Ch. T 000842 I->	01.88 12.91		AM.2255G				AM.1330G

ESPACE II (J/S63_)

 Exc. Exc. 3.0 V6	01.91 12.96		AM.2256G				AM.1330G
3.0 V6 Exc.	01.91 12.96		AM.2256G				AM.1330G
	01.91 12.96		AM.2256G				

ESPACE III (JE_)

2.0, 2.0 16v 2,7 m = Incl.	01.96 12.02		AM.3148G				AM.1233G
3.0 V6, 3.0 2.2 dT, 2.2 dCi, 1.9 dTi 2,7 m = Incl.	01.96 12.02		AM.3148G				AM.1233G

ESPACE III, GRAND ESPACE (JE_)

2.0, 2.0 16v 2.2 dT, 2.2 dCi, 1.9 dTi 2,9 m. = Incl.	01.97 12.02		AM.3148G				AM.2234G
3.0 V6, 3.0 2,9 m. = Incl.	01.97 12.02		AM.3148G				AM.2234G

... RENAULT (F)

HYDRO TECH
TOP ROAD GAS

HYDRO TECH
TOP ROAD GAS

ESPACE IV (JK0_)

	11.02 ⇄ 08.04		3203G*				AM.2155G*
--	---------------	--	--------	--	--	--	-----------

EXPRESS, EXTRA, RAPID (F40_, G40_)

Utilitaire, Express, Extra, Rapid F 40 Exc. CU+	01.85 ⇄ 10.96		AM.3658 ^B			S026	AM.1659	AM.1659G
Utilitaire, Express, Extra, Rapid CU+ 775 Kg.	01.91 ⇄ 10.96		AM.3658 ^B			S026		AM.2017G
Utilitaire, Express, Extra, Rapid F 40 Exc. CU+	11.96 ⇄		AM.3015			S026	AM.1659	AM.1659G
Utilitaire, Express, Extra, Rapid CU+ 775 Kg.	11.96 ⇄		AM.3015			S026		AM.2017G

FUEGO (R 136_)

TL, GTL R 1360, R 1361	01.80 ⇄ 12.85		AM.2516				AM.1254
GTS, GTX R 1362, R 1363	01.80 ⇄ 12.85		AM.2516				AM.1254
Turbo Diesel R 1366	01.82 ⇄ 12.85		AM.2516				AM.1254
Turbo R 1365	01.84 ⇄ 12.85		AM.2516				AM.1254

KANGOO (KC0_, FC0_)

1.2, 1.2 16v, 1.4, 1.6 16v 1.5 dCi, 1.9 D 55, 1.9 D 65, 1.9 dCi, 1.9 dTi 580 Kg. Exc. CU+ Exc. Pampa	09.97 ⇄		AM.3092		L011		AM.1176
1.4, 1.6 16v 1.5 dCi, 1.9 D 55, 1.9 D 65, 1.9 dCi, 1.9 dTi 750 Kg. Exc. Pampa	09.97 ⇄		AM.3092		L011		AM.2706G



... RENAULT (F)



HYDRO TECH

TOP ROAD GAS



HYDRO TECH

TOP ROAD GAS



LAGUNA I (B56_, 556_)

1.8, 2.0 Ch. 950421	01.94 ⇄ 12.96			AM.3024G ⁹	L010	S006			AM.2031G
1.8, 2.0 8v (84 kW) Ch. 950422 ⇄ 	01.96 ⇄ 12.00		AM.3023 ⁹	AM.3023G ⁹	L010	S006			AM.2031G
1.6	01.99 ⇄ 12.00		AM.3023 ⁹	AM.3023G ⁹	L010	S006			AM.2031G
1.8, 2.0 8v (84 kW) Ch. 950422 ⇄ 	01.96 ⇄ 12.00			AM.3024G ⁹	L010	S006			AM.2031G
3.0 V6 2.2 D, 2.2 dt	01.94 ⇄ 12.00			AM.3024G ⁹	L010	S006			AM.2031G
2.0 16v (103 kW)	01.96 ⇄ 12.00			AM.3024G ⁹	L010	S006			AM.2031G
1.9 dTi, 1.9 dCi	01.98 ⇄ 12.00			AM.3024G ⁹	L010	S006			AM.2031G

LAGUNA I NEVADA (K56_)

1.8, 2.0	07.95 ⇄ 12.00			AM.3024G ⁹	L010	S006			AM.2032G
1.6 1.9 dTi, 1.9 dCi	01.99 ⇄ 12.00			AM.3024G ⁹	L010	S006			AM.2032G
3.0 V6 2.2 D, 2.2 dT	07.95 ⇄ 12.00			AM.3024G ⁹	L010	S006			AM.2032G

9

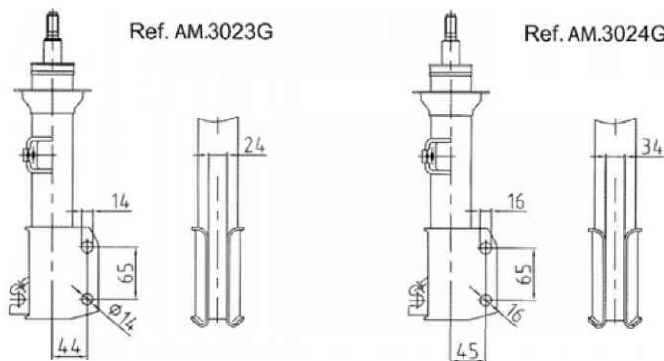

LAGUNA II (B74_)

1.6, 1.8, 2.0 1.9 dCi, 2.2 dCi	10.00 ⇄			AM.3149G					AM.1231G
-----------------------------------	---------	--	--	----------	--	--	--	--	----------

LAGUNA II GRANDTOUR (K74_)

1.6, 1.8, 2.0 1.9 dCi, 2.2 dCi	10.00 ⇄			AM.3149G					AM.1232G
-----------------------------------	---------	--	--	----------	--	--	--	--	----------

MEGANE I (BA)

1.4, 1.4 16v, 1.6, 1.6 16v, 2.0 1.9 D, 1.9 dCi, 1.9 dTi, 1.9 TD Exc. 2.0 16v	09.95 ⇄ 12.02			AM.3050G	L010	S026			AM.1881G
--	---------------	--	--	----------	------	------	--	--	----------

SUSPENSION, DIRECCION Y TRANSMISION / SUSPENSION, TRANSMISSION ET DIRECTION / SUSPENSION, TRANSMISSION AND STEERING

... RENAULT (F)

**HYDRO
TECH**
**TOP
ROAD
GAS**

**HYDRO
TECH**
**TOP
ROAD
GAS**

MEGANE I CLASSIC (LA)

1.4, 1.4 16v, 1.6, 1.6 16v, 2.0 1.9 D, 1.9 dCi, 1.9 dTi	01.96 ⇌ 12.03		AM.3050G	L010	S026		AM.1881G
--	---------------	--	----------	------	------	--	----------

MEGANE I (DA0/1_)

1.4 16v, 1.6, 1.6 16v, 2.0 1.9 dCi, 1.9 dTi Exc. 2.0 16v	09.96 ⇌ 12.02		AM.3050G	L010	S026		AM.1881G
--	---------------	--	----------	------	------	--	----------

MEGANE I (EA0_)

1.4 16v, 1.6, 1.6 16v Exc. 2.0 16v	02.97 ⇌ 12.03		AM.3050G	L010	S026		
---------------------------------------	---------------	--	----------	------	------	--	--

MEGANE I GRANDTOUR (KA)

1.4, 1.4 16 v, 1.6, 1.6 16v 1.9 D, 1.9 dCi, 1.9 dTi	03.99 ⇌		AM.3050G	L010	S026		AM.2114G
--	---------	--	----------	------	------	--	----------

MEGANE I SCENIC (FAO_, JAO_) 2WD

1.4, 1.4 16v, 1.6 16v 1.6 JAOL	11.96 ⇌ 12.03		AM.3050G	L010	S026		AM.2080G
1.6 JAOF 	11.96 ⇌ 12.03		AM.3050G	L010	S026		AM.2080G
1.6 JAOF 	11.96 ⇌ 06.98		AM.3051G	L010	S026		AM.2080G
1.6 JAOF 	07.98 ⇌ 12.03		AM.3050G	L010	S026		AM.2080G
1.9 D JAOK, JAOY	11.96 ⇌ 12.03		AM.3051G	L010	S026		AM.2080G
2.0 1.9 D, 1.9 dTi FAOJ, FAOK, FAOY, JAOJ	11.96 ⇌ 06.98		AM.3051G	L010	S026		AM.2080G
2.0 1.9 dTi, 1.9 dCi	07.98 ⇌ 12.03		AM.3050G	L010	S026		AM.2080G

MEGANE II (BM0_, CM0)

1.4 16v, 1.6 16v, 2.0 16v 1.5 dCi, 1.9 dCi 	11.02 ⇌		AM.3204DG* AM.3204IG*				AM.1350G*
1.4 16v, 1.6 16v, 2.0 16v 1.5 dCi, 1.9 dCi 	11.02 ⇌		AM.3204DG* AM.3204IG*				AM.1351G*

**... RENAULT (F)****HYDRO
TECH****TOP
ROAD
GAS****HYDRO
TECH****TOP
ROAD
GAS****MEGANE II** 1.4 16v, 1.6 16v, 2.0 16v
1.5 dCi, 1.9 dCi

09.03 ⇨

AM3204DG*
AM3204IG*

AM.1350G*

1.4 16v, 1.6 16v, 2.0 16v
1.5 dCi, 1.9 dCi

09.03 ⇨

AM3204DG*
AM3204IG*

AM.1351G*

**MEGANE II** 1.6 16v, 2.0 16v
1.9 dCi

09.03 ⇨

AM3204DG*
AM3204IG***MEGANE II GRANDTOUR** 1.4 16v, 1.6 16v, 2.0 16v
1.5 dCi, 1.9 dCi

09.03 ⇨

AM3204DG*
AM3204IG*

AM.1352G*

MEGANE II SCENIC (JM) 1.4 16v, 1.6 16v, 2.0 16v
1.5 dCi, 1.9 dCi

06.03 ⇨

AM3205DG*
AM3205IG*

AM.1353G*

MEGANE II GRAND SCENIC

Grand Scenic

04.04 ⇨

AM3205DG*
AM3205IG*

AM.1354G*

R 4 (R 112_)

R 1120, R 1124

01.61 ⇨ 08.68



AM.1024



AM.1025

R 1120, R 1123

09.68 ⇨ 12.92



AM.1026

AM.1026G



AM.1025

R 1126

02.71 ⇨ 12.92



AM.1026

AM.1026G



AM.1025

R 1128 GTL

01.78 ⇨ 12.92



AM.1026

AM.1026G



AM.1025

Rodeo

01.73 ⇨ 12.92



AM.1026

AM.1026G

R 4 FOURGONNETTE (R 210_, R 23_)

R 2102, R 2106

01.61 ⇨ 08.68



AM.1024



AM.1025

R 2105, R 2106, R 2109,
F 4

09.68 ⇨



AM.1026

AM.1026G



AM.1025

R 2340, R 2370
F 6

01.75 ⇨



AM.1026

AM.1026G

... RENAULT (F)

**HYDRO
TECH**
**TOP
ROAD
GAS**

**HYDRO
TECH**
**TOP
ROAD
GAS**

R 5 (R 122_, R 139_, R 238_)

R 1220, R 1221, R 1222, R 1225, R 1227 L, TL, GTL	02.72 12.79		AM.1026	AM.1026G				AM.1027	AM.1027G
R 1391, R 1395, R 1397, R 1399 L, TL, GTL	01.80 12.84		AM.1026	AM.1026G				AM.1027	AM.1027G
R 1224, R 1229, R 1394, R 2381, R 2382, R 2387 LS, TSX TX Societé	01.74 12.84		AM.1026	AM.1026G				AM.1027	AM.1027G

R 5 SUPER 5 (B/C/S40_)

B, C, S Exc. GT Turbo	01.84 07.85		AM.3658 ⁸			S026		AM.1659	AM.1659G
GT Turbo C405	01.84 07.85								AM.1856G
B, C, S Exc. GT Turbo Exc. GTE	08.85 05.88		AM.3696 ⁸	AM.3696G ⁸		S026		AM.1659	AM.1659G
B, C, S Exc. GT Turbo Exc. GTE	06.88 03.95		AM.3696 ⁸ AM.3875 ⁸	AM.3696G ⁸		S026		AM.1659	AM.1659G
GT Turbo C405	08.85 05.87		AM.3821			S026			AM.1856G
GT Turbo C405	06.87 08.90		AM.3821			S026			AM.1856G
GTE C409	01.87 08.91		AM.3821			S026			AM.1856G

R 5 SUPER 5 (F40_, S40_)

Utilitaire, Express, Extra, Rapid F 40 Exc. CU+	01.85 10.96		AM.3658 ⁸			S026		AM.1659	AM.1659G
Utilitaire, Express, Extra, Rapid CU+ 775 Kg.	01.91 10.96		AM.3658 ⁸			S026			AM.2017G
Utilitaire, Express, Extra, Rapid F 40 Exc. CU+	11.96 03.98		AM.3015			S026		AM.1659	AM.1659G
Utilitaire, Express, Extra, Rapid CU+ 775 Kg.	11.96 03.98		AM.3015			S026			AM.2017G



... RENAULT (F)



HYDRO TECH

TOP ROAD GAS



HYDRO TECH

TOP ROAD GAS



8

Ref. AM.3658,AM.3696,AM.3696G

Ref.AM.3875

Ref. AM.3847

Ref. AM.3855, AM.3855G

Ref.AM.3089



OE:
77 00 732 743
77 00 732 744
77 00 807 874
77 00 145 522
77 02 145 523

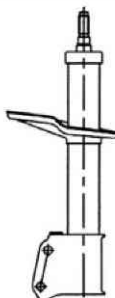

OE:
77 00 786 597
77 00 807 873
77 02 150 468



OE:
77 00 808 490
77 00 816 045
77 00 823 130
77 00 828 680
77 00 838 084



OE:
77 00 808 491
77 00 808 492
77 00 816 046
77 00 823 129
77 00 823 131
77 00 828 681
77 00 828 682
77 00 838 083
77 00 838 087



OE:
77 00 423 726
77 00 423 727
77 00 423 729

R 6 (R 118_)

R 1180, R 1181	01.68 12.81		AM.1026	AM.1026G				AM.1025	
Rodeo	01.73 12.87		AM.1026	AM.1026G					

R 9 (L42_)

C, TC, GTC, TL, TLE, TSE, GTL, GTE, TD, GTD, TDE L 421, L 422, L 423, L 424, L 42 J, L 42 S <small>Auto Incl.</small>	01.82 12.90		AM.3418	AM.3418G	L010	S026		AM.1419	AM.1419G
TX, GTX, TXE L 42 F Ch. D 000525	01.85 12.86		AM.3418	AM.3418G	L010	S026		AM.1419	AM.1419G
TX, GTX, TXE L 426 Ch. D 003950 Ch. H 005600	01.85 12.86		AM.3418	AM.3418G	L010	S026		AM.1419	AM.1419G

R 9 (B37_, C37_, L42_)

TX, GTX, TXE L 42 F Ch. D 000526 >	01.86 12.90		AM.3418	AM.3418G	L010	S026		AM.1801	AM.1801G
TX, GTX, TXE L 426 Ch. D 003951 > Ch. D 005601 >	01.86 12.90		AM.3418	AM.3418G	L010	S026		AM.1801	AM.1801G
TX, GTX, TXE L 42 L, L 42 N	10.86 12.90		AM.3418	AM.3418G	L010	S026		AM.1801	AM.1801G
GTE L 42 E B 37 E C 37 E	01.87 12.90		AM.3418	AM.3418G	L010	S026		AM.1801	AM.1801G
Turbo L 425	01.85 12.90		AM.3418	AM.3418G	L010	S026		AM.1801	AM.1801G
Turbo B 375 Ch. D 001344 >	01.86 12.90		AM.3418	AM.3418G	L010	S026		AM.1801	AM.1801G
Turbo C 375 Ch. D 007887 > Ch. E 002301 >	01.86 12.90		AM.3418	AM.3418G	L010	S026		AM.1801	AM.1801G

SUSPENSION, DIRECCION Y TRANSMISION / SUSPENSION, TRANSMISSION ET DIRECTION / SUSPENSION, TRANSMISSION AND STEERING

... RENAULT (F)

**HYDRO
TECH**
**TOP
ROAD
GAS**

**HYDRO
TECH**
**TOP
ROAD
GAS**

R 11 (B/C/S37_) 2

TC, TCE, TL, TLE, TSE, GTC, GTL, TD, GTD, TDE B 371, B 372, B 373, B 374, B 37 S, B 37 J C 371, C 372 	01.83 12.90		AM.3418 AM.3418G	L010	S026		AM.1419 AM.1419G
S 371, S 372, S 373, S 374, S 375	01.84 12.90		AM.3418 AM.3418G	L010	S026		AM.1419 AM.1419G
TX, GTX, TXE B 37 F Ch. ⇒ D 000645 	01.85 12.86		AM.3418 AM.3418G	L010	S026		AM.1419 AM.1419G
TX, GTX, TXE C 37 F Ch. ⇒ D 000509	01.85 12.86		AM.3418 AM.3418G	L010	S026		AM.1419 AM.1419G
TX, GTX, TXE B 376 Ch. ⇒ D 043789 Ch. ⇒ H 017726 	01.84 12.86		AM.3418 AM.3418G	L010	S026		AM.1419 AM.1419G
TX, GTX, TXE C 376 Ch. ⇒ D 006418	01.84 12.86		AM.3418 AM.3418G	L010	S026		AM.1419 AM.1419G
Turbo B 375 Ch. ⇒ D 001343	01.85 12.86		AM.3418G	L010	S026		AM.1419G
Turbo C 375 Ch. ⇒ D 007886 Ch. ⇒ E 002300	01.84 12.86		AM.3418G	L010	S026		AM.1419G

R 11 (B/C37_, L42_) 4

TX, GTX, TXE B 37 F Ch. D 000646 ⇒ 	01.86 12.90		AM.3418 AM.3418G	L010	S026		AM.1801 AM.1801G
TX, GTX, TXE B 376 Ch. D 043790 ⇒ Ch. H 017727 ⇒	01.86 12.90		AM.3418 AM.3418G	L010	S026		AM.1801 AM.1801G
TX, GTX, TXE C 37 F Ch. D 000510 ⇒	01.86 12.90		AM.3418 AM.3418G	L010	S026		AM.1801 AM.1801G
TX, GTX, TXE C 376 Ch. D 006419 ⇒	01.86 12.90		AM.3418 AM.3418G	L010	S026		AM.1801 AM.1801G
TX, GTX, TXE B 37 L, B 37 N C 37 L, C 37 N 	10.86 12.90		AM.3418 AM.3418G	L010	S026		AM.1801 AM.1801G
GTE L 42 E, B 37 N C 37 L, C 37 N	01.87 12.90		AM.3418 AM.3418G	L010	S026		AM.1801 AM.1801G
Turbo L 425	01.85 12.90		AM.3418G	L010	S026		AM.1801G
Turbo B 375 Ch. D 001344 ⇒	01.86 12.90		AM.3418G	L010	S026		AM.1801G
Turbo C 375 Ch. D 007887 ⇒ Ch. E 002301 ⇒	01.86 12.90		AM.3418G	L010	S026		AM.1801G

**... RENAULT (F)****HYDRO
TECH****TOP
ROAD
GAS****HYDRO
TECH****TOP
ROAD
GAS****R 12 EQUIPEMENT PISTES**

	01.69 ⇄ 09.72		AM.2056					AM.1226		
	10.72 ⇄ 12.79		AM.2056					AM.1226		

R 12, R 15, R 17

R 12	01.69 ⇄ 04.70		AM.2056					AM.1226		
R 12 R 1170, R 1177	05.70 ⇄ 12.79		AM.2058					AM.1226		
R 15	01.71 ⇄ 12.79		AM.2058					AM.1226		
R 17	01.71 ⇄ 12.79		AM.2058					AM.1226		

R 14 (R 121_)

L, TL, GTL R 1210 Ch. ⇒ 0345946	01.76 ⇄ 12.79		AM.8926			S009		AM.1027	AM.1027G	
LS, TS R 1211 Ch. ⇒ 0007533	01.77 ⇄ 12.78		AM.8926			S009		AM.1027	AM.1027G	
L, TL, GTL R 1210, R 1213 Ch. 0345947 ⇄	01.78 ⇄ 12.83		AM.8324			S022		AM.1027	AM.1027G	
LS, TS R 1211, R 1212 Ch. 0007534 ⇄	01.78 ⇄ 12.83		AM.8324			S022		AM.1027	AM.1027G	

R 16 (R 115_)

R 1150, R 1152, R 1154	01.65 ⇄ 12.79		AM.1343					AM.1503		
------------------------	---------------	--	---------	--	--	--	--	---------	--	--

R 18 (R 134_)

TL, GTL R 1340 Ch. ⇒ 0552000	⇒ 12.84		AM.2253					AM.1254		
TS, GTS R 1341 Ch. ⇒ 0559400	⇒ 12.84		AM.2253					AM.1254		
TS, GTS R 1342 Ch. 0010710 ⇄ 0020609	01.83 ⇄		AM.2253					AM.1254		
TS, GTS R 1342 Ch. ⇒ 0010709	⇒ 12.82		AM.2428					AM.1254		
TX, GTX R 1343 Ch. ⇒ 0003200	⇒ 12.83		AM.2428					AM.1254		
TD, GTD R 1344 Ch. ⇒ 0190905	⇒ 12.84		AM.2428					AM.1254		
TL, GTL R 1340 Ch. 0552001 ⇄	01.84 ⇄ 12.86		AM.2516					AM.1254		
TS, GTS R 1341 Ch. 0559401 ⇄	01.84 ⇄ 12.86		AM.2516					AM.1254		
TS, GTS R 1342 Ch. 0020610 ⇄	01.83 ⇄ 12.86		AM.2516					AM.1254		

... RENAULT (F)

**HYDRO
TECH**
**TOP
ROAD
GAS**

**HYDRO
TECH**
**TOP
ROAD
GAS**

... R 18 (R 134_)

TX, GTX R 1343 Ch. 0003201 >	01.84 > 12.86		AM.2516					AM.1254	
TD, GTD R 1344 Ch. 0190906 >	01.84 > 12.86		AM.2516					AM.1254	
Turbo R 1345	01.82 > 12.86		AM.2516					AM.1254	
Turbo Diesel R 1346	01.84 > 12.86		AM.2516					AM.1254	

R 18 (R 135_, R 235_) 2WD

TL R 1350 Ch. => 0122600	=> 12.84		AM.2253					AM.1254	
TL, LS, GTL R 1351 Ch. => 0118200	=> 12.84		AM.2253					AM.1254	
GTS R 1352 Ch. => 0003929	=> 12.83		AM.2253					AM.1254	
Société R 2350 Ch. => 0004600	=> 12.80		AM.2253					AM.1254	
TX, GTX R 1353 Ch. => 0002000	=> 12.82		AM.2428					AM.1254	
TD, GTD R 1354 Ch. => 0063219	=> 12.84		AM.2428					AM.1254	
Société R 2354 Ch. => 0003499	=> 12.83		AM.2428					AM.1254	
TL R 1350 Ch. 0122601 >	01.84 > 12.86		AM.2516					AM.1254	
TL, LS, GTL R 1351 Ch. 0118201 >	01.84 > 12.86		AM.2516					AM.1254	
GTS R 1352 Ch. 0003930 >	01.83 > 12.86		AM.2516					AM.1254	
TX, GTX R 1353 Ch. 0002001 >	01.83 > 12.86		AM.2516					AM.1254	
TD, GTD R 1354 Ch. 0063220 >	01.84 > 12.86		AM.2516					AM.1254	
Turbo R 1355	01.83 > 12.86		AM.2516					AM.1254	
Turbo Diesel R 1356	01.84 > 12.86		AM.2516					AM.1254	
Société R 2350 Ch. 0004601 >	01.84 > 12.86		AM.2516					AM.1254	
Société R 2354 Ch. 0003500 >	01.83 > 12.86		AM.2516					AM.1254	

R 19 (B/C53_, L53_) 2

1237, 1397, 1390 1870 Diesel	01.88 > 12.96		AM.3803	AM.3803G	L010	S026		AM.1804	AM.1804G
---------------------------------	----------------	--	---------	----------	------	------	--	---------	----------



... RENAULT (F)



HYDRO TECH



TOP ROAD GAS







HYDRO TECH





TOP ROAD GAS

















R 19 (B/C53_, L53_)   



1721, 1794	01.88 12.96		AM.3803	3803G	L010	S026		AM.1877G
1870 Turbo Diesel	01.91 12.96		AM.3803	3803G	L010	S026		AM.1877G
1764 16v - 16s	01.88 12.96							AM.1877G

















R 19 (D53_) 

 Exc. 16v - 16s	04.92 06.96		AM.3803	3803G	L010	S026		AM.1877G
16v - 16s	04.92 06.96							AM.1877G

R 20 (R 127_) 

TL, GTL R 1271	01.76 12.80		AM.2518					AM.8519
TS, LS R 1272	01.78 12.84		AM.2518					AM.3802
TL, GTL R 1271	01.80 12.84		AM.2682					AM.3802
TL, GTL R 1270	01.82 12.84		AM.2682					AM.3802
TD, GTD R 1276	01.80 12.84		AM.2682					AM.3802
LS, TS R 1277	01.81 12.84		AM.2682					AM.3802
TX R 1279	01.81 12.84		AM.2681					

R 21 (L48)  

1.4 TL, GTL	06.88 12.94		AM.3805			S006		AM.2806 AM.1806G
1.7 TL, GTL, TS, GTS, RS, TSE	03.86 12.94		AM.3805			S006		AM.2806 AM.1806G
1.9 SD, GSD Diesel	05.89 12.94		AM.3805			S006		AM.2806 AM.1806G
2.0 TX, GTS, GTX L 48 J	03.86 12.94		AM.3805			S006		AM.2806 AM.1806G
1.7 TL L 48 K  	03.86 12.94		AM.3807 AM.3808					AM.2806 AM.1806G
2.0 RX, TX, Ti, GTX, TXE, GTS L 483, L 489, L 48 K  	03.86 12.94		AM.3807 AM.3808					AM.2806 AM.1806G

SUSPENSION, DIRECCION Y TRANSMISION / SUSPENSION, TRANSMISSION ET DIRECTION / SUSPENSION, TRANSMISSION AND STEERING

... RENAULT (F)

**HYDRO
TECH**
**TOP
ROAD
GAS**

**HYDRO
TECH**
**TOP
ROAD
GAS**

... R 21 (L48) 2WD

2.0 TXi L 84 Q 2WD	05.89 12.94		AM.3807 AM.3808					AM.2806 AM.1806G
2.1 TD, GTD Diesel 	03.86 12.94		AM.3807 AM.3808					AM.2806 AM.1806G
2.1 TBD, TDX Turbo Diesel 	03.86 12.94		AM.3807 AM.3808					AM.2806 AM.1806G
2.2 RX, GTX, TXE 	01.86 12.94		AM.3807 AM.3808					AM.2806 AM.1806G

R 21 (B48_) 2WD

1.4 TL, GTL, TS, GTS	06.89 06.94		AM.3805			S006		AM.2806 AM.1806G
1.7 TL, GTL, TS, GTS, TSE	06.89 06.94		AM.3805			S006		AM.2806 AM.1806G
1.9 SD, GSD Diesel	06.89 06.94		AM.3805			S006		AM.2806 AM.1806G
2.0 TXE B 48 J	06.89 06.94		AM.3805			S006		AM.2806 AM.1806G
2.0 TX, GTX, TXi, TXE B 483, B 48 K 	06.89 06.94		AM.3807 AM.3808					AM.2806 AM.1806G
2.1 TD, GTD Diesel 	06.89 06.94		AM.3807 AM.3808					AM.2806 AM.1806G
2.1 TBD, TDX Turbo Diesel 	06.89 06.94		AM.3807 AM.3808					AM.2806 AM.1806G

R 21 NEVADA (K48_) 2WD

1.6 RX 1.7 TL, TS, GTL, GTS 1.9 D, SD, GSD Diesel 2.0 RX K 48 J	03.86 08.94		AM.3805			S006		AM.1118 AM.1118G
2.0 RX K 483 2.0 GTX, TXE 2.1 D, TD, GTD Diesel & Turbo Diesel 2.2 GTX, TXE 	03.86 08.94		AM.3807 AM.3808					AM.1118 AM.1118G
2.0 RX K 483 2.0 GTX, TXE 2.1 D, TD, GTD Diesel & Turbo Diesel 2.2 GTX, TXE 	03.86 08.94		AM.3807 AM.3808					AM.1118 AM.1118G

**... RENAULT (F)****HYDRO
TECH****TOP
ROAD
GAS****HYDRO
TECH****TOP
ROAD
GAS****R 25 (B29_)**

 Exc. V6 Exc. Turbo Diesel	01.84 ⇌ 12.92		AM.2809					AM.3810	AM.3810G
V6 Turbo Diesel	01.84 ⇌ 12.92		AM.2809					AM.3810	AM.3810G

R 30 (R 127_)

TS R 1273, R 1275	01.75 ⇌ 12.84		AM.2518					AM.3802	
Turbo Diesel R 1270	01.82 ⇌ 12.84		AM.2682					AM.3802	
TX R 1278 Ch. 0022200	01.79 ⇌ 12.80		AM.2518					AM.3802	
TX R 1278 Ch. 0022201 ⇌	01.80 ⇌ 12.84							AM.2681 AM.3802	

SAFRANE I, II (B54_)

2.0, 2.2, 3.0 V6 2.1 dT, 2.5 dT 	01.92 ⇌ 10.96			AM.3009DG AM.3009IG	L010	S006			AM.3010G
2.0, 2.5, 3.0 V6 2.2 dT 	11.96 ⇌ 12.00			AM.3009DG AM.3009IG	L010	S006			AM.3010G

TWINGO I (C06_, S06_)

1.1, 1.2	01.93 ⇌ 12.98		AM.3017		L011	S025		AM.1071	
----------	---------------	--	---------	--	------	------	--	---------	--

TWINGO II (C06_, S06_)

1.2	01.98 ⇌ 08.00		AM.3161					AM.1071	
-----	---------------	--	---------	--	--	--	--	---------	--

TWINGO III (C06_)

1.2 16v	09.00 ⇌		AM.3225*						AM.1225G
---------	---------	--	----------	--	--	--	--	--	----------



RENAULT COMMERCIALS (F)



HYDRO TECH

TOP ROAD GAS



HYDRO TECH

TOP ROAD GAS



KANGOO (KC0_, FC0_)

1.2, 1.2 16v, 1.4, 1.6 16v
1.5 dCi, 1.9 D 55, 1.9 D 65,
1.9 dCi, 1.9 dTi

580 Kg.

1 x 4WD
Exc.

Exc. CU+

Exc. Pampa

09.97 ⇨



AM.3092

L011



AM.1176

1.4, 1.6 16v
1.5 dCi, 1.9 D 55, 1.9 D 65,
1.9 dCi, 1.9 dTi

750 Kg.

2 x 4WD
Exc.

Exc. Pampa

09.97 ⇨



AM.3092

L011



AM.2706G

R 4 FOURGONNETTE (R 210_, R 23_)

R 2102, R 2106

01.61 ⇨ 08.68



AM.1024



AM.1025

R 2105, R 2106, R 2109
F 4

09.68 ⇨



AM.1026

AM.1026G



AM.1025

R 2340, R 2370
F 6

01.75 ⇨



AM.1026

AM.1026G

R 5 SUPER 5 (F40_)

Utilitaire, Express, Extra, Rapid
F 40

01.85 ⇨ 10.96



AM.3658⁸

S026



AM.1659

AM.1659G

Utilitaire, Express, Extra, Rapid
CU+

775 Kg.

01.91 ⇨ 10.96



AM.3658⁸

S026



AM.2017G

Utilitaire, Express, Extra, Rapid
F 40

11.96 ⇨ 03.98



AM.3015

S026



AM.1659

AM.1659G

Utilitaire, Express, Extra, Rapid
CU+

775 Kg.

11.96 ⇨ 03.98



AM.3015

S026



AM.2017G

8

Ref. AM.3658, AM.3696, AM.3696G

Ref. AM.3875

Ref. AM.3847

Ref. AM.3855, AM.3855G

Ref. AM.3089



OE:
77 00 732 743
77 00 732 744
77 00 807 874
77 00 145 522
77 02 145 523

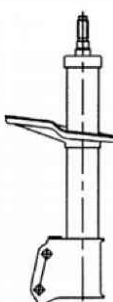

OE:
77 00 786 597
77 00 807 873
77 02 150 468



OE:
77 00 808 490
77 00 816 045
77 00 823 130
77 00 828 680
77 00 838 084



OE:
77 00 808 491
77 00 808 492
77 00 816 046
77 00 823 129
77 00 823 131
77 00 828 681
77 00 828 682
77 00 838 083
77 00 838 087



OE:
77 00 423 726
77 00 423 727
77 00 423 729

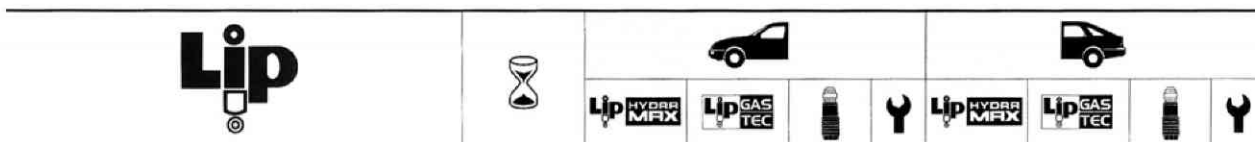

RENAULT

R 4 / R4 F6

	10/62 → 08/68	AP:126050	↓	AP:126075	OT
	09/68 → 92	AP:126070	↓	AP:126075	OT
4 F	10/62 → 08/68	AP:126050	↓	AP:126074	OT
4 F	09/68 → 92	AP:126070	↓	AP:126074	OT
4 F 6		AP:126070	↓	AP:126077	OT

R 5

	01/72 → 12/84	AP:126071 AP:126049	↑	AP:177015 AP:177016 AP:127236	↓	AP:127116	↓	AP:177016 AP:127236	↓	LO
--	---------------	------------------------	---	-------------------------------------	---	-----------	---	------------------------	---	----

SUPER 5 (B/C40)

	01/85 → 11/85	AP:129037	↑	AP:177001	OO		
	11/85 → 05/88	AP:129142 AP:178142 AP:300034	↑	AP:177001	OO		
	06/88 → 03/95	AP:129143 AP:178143 AP:300034	↑	AP:177001	OO		
1.6 D	01/85 → 11/85	AP:129037	↑	AP:177001	OO		
1.6 D	11/85 → 03/95	AP:129142 AP:178142 AP:300034	↑	AP:177001	OO		
GT Turbo	C405	01/85 → 07/87	AP:129071	AP:300034	↑	AP:177005	OO
GT Turbo	C405	07/87 → 08/90	AP:129083		↑	AP:177005	OO
GTE	C409	1987 → 08/91	AP:129071		↑	AP:177005	OO

<p>AP.129.143/AP.178.143</p> <p>Orig N</p> <p>77 02 150 468 77 00 786 597 77 00 807 873</p>	<p>AP.129.142/AP.178.142</p> <p>Orig N</p> <p>77 00 732 743 77 00 732 744 77 02 145 522 77 02 145 523 77 00 807 874</p>
---	---

SUPER 5 COPA (Competition Vehicles Only)

Copa Turbo	01/85 → 12/88	AP:129083	↑		OO
Copa Turbo	01/89 →		↑		OO
Copa Iniciación	01/85 →		↑	AP:177002 *	OO

R 6

	1969 → 70	AP:126050	↓	AP:126074	OT
	1971 → 74	AP:126072	↓	AP:126074	OT
	1975 → 04/87	AP:126072	↓	AP:126008	OT

R 7

	01/72 → 12/84	AP:126071 AP:126049	↑	AP:177015 AP:177016 AP:127236	↓	AP:127116	↓	AP:177016 AP:127236	↓	LO
--	---------------	------------------------	---	-------------------------------------	---	-----------	---	------------------------	---	----

LipGasTec Lip 4x4

RENAULT
R 9 (L42_)

1.1	L421, 422, 423, 424, 42S	03/82 → 03/87	AP129017	AP178017	AP300030	↓	AP127138	AP177013	LO
1.1	L421, 422, 423, 424, 42J	04/87 → 90	AP129085	AP178085	AP300030	↓			
1.2	L421, 422, 423, 424, 42J	10/85 → 03/87	AP129017	AP178017	AP300030	↓			
		04/87 → 90	AP129085	AP178085	AP300030	↓			
1.4	L421, 422, 423, 424, 42J	03/82 → 03/87	AP129017	AP178017	AP300030	↓			
		04/87 → 90	AP129085	AP178085	AP300030	↓			
1.6 D	L421, 422, 423, 424, 42J	12/82 → 03/87	AP129017	AP178017	AP300030	↓			
		04/87 → 90	AP129085	AP178085	AP300030	↓			
1.7	L42F, 426 → veh.nº D525, D3950, H5600	1985 → 86	AP129017	AP178017	AP300030	↓			

R 9 (L42_)

1.4 Turbo L425		1985 → 90		AP178085	AP300030	↓	AP127247	AP177054	LO
1.4 Turbo B375	veh.nº D1344 →	1986 → 90							
1.4 Turbo C375	veh.nº D7887, D2301 →	1986 → 90							
1.7 L42F, 426, 42L, 42N	→ veh.nº D525, D3950, H5600	1986 → 03/87	AP129017	AP178017	AP300030	↓			
1.7 L42F	→ veh.nº D525, D3950, H5600	04/87 → 90	AP129085	AP178085	AP300030	↓			
1.7 Turbo L425		1985 → 90		AP178085	AP300030	↓			
1.7 Turbo B375	veh.nº D1244 →	1986 → 90							
1.7 Turbo C375	veh.nº D7887, D2301 →	1986 → 90							

R 11 (B/C37_)

1.1	B / C371 / S / J	03/83 → 09/86	AP129017	AP178017	AP300030	↓	AP127138	AP177013	LO
1.4	B/C371 / 372 / 373 / 374/S	1983 → 03/87	AP129017	AP178017	AP300030	↓			
		04/87 → 90	AP129085	AP178085	AP300030	↓			
1.6 D	B/C371 / 372 / 373 / 374/S	1983 → 03/87	AP129017	AP178017	AP300030	↓			
		1987 → 90	AP129085	AP178085	AP300030	↓			
1.7 B37F	→ veh.nº D645	1985 → 86	AP129017	AP178017	AP300030	↓			
1.7 B367	→ veh.nº D43789, D17726	1984 → 86							
1.7 C37F	→ veh.nº D509	1985 → 86							
1.7 C 376	→ veh.nº D6418	1984 → 86							
GTX, Turbo (B/C 375)		→ 08/85	AP129047		AP300030	↓			LO

R 11 (B/C37_)

1.7 B, C37		1986 → 03/87	AP129017	AP178017	AP300030	↓	AP127247	AP177054	LO
1.7 B/C37L, 37N									
1.7 B37F	veh.nº D646 →								
1.7 B376	veh.nº D43790, H17727 →								
1.7 C37F	veh.nº D510 →								
1.7 C376	veh.nº D6419 →								
1.7 B/C37L, 37N		04/87 → 90	AP129085	AP178085	AP300030	↓			
1.7 B37F	veh.nº D646 →								
1.7 B376	veh.nº D43790, H17727 →								
1.7 C37F	veh.nº D510 →								
1.7 C376	veh.nº D6419 →								
GTX, TXE, Turbo (B/C 376)		09/85 → 90	AP129047	AP178085	AP300030	↓			

R 12

		1969 → 04/70				↓	T		LT
		06/72 → 02/74	AP127003 *			↓	T		LT
		03/74 → 12/78	AP127117			↓	T	AP127005	LT
		01/79 →	AP127117			↓	T	AP127244	LT

LipGasTec
Lip 4x4

**RENAULT****R 14 (121_)**

L, TL, GTL (R1210)	->ch. 0345946	1976 ->79	AP129176	⌋	AP127116	⌋	AP.177016	⌋	⌋
LS, TS (R1211)	->ch. 0007533	1977 ->78					AP.127236	⌋	*
L, TL, GTL (R1210, R1213)	ch. 0345947 ->	1978 ->83	AP129012	⌋	AP127121				⌋
LS, TS (R1211, R1212)	ch. 0007534 ->	1978 ->83							⌋

R 15 / R 17

		1971 ->79		⌋	⌋	AP127005			⌋	⌋
--	--	-----------	--	---	---	----------	--	--	---	---

R 18 (134_, 135_)

Diesel, GTX, Turbo			AP127119	⌋	⌋	AP127120				⌋	⌋
Diesel	->05/83		AP127161	⌋	⌋	AP127162					⌋
Diesel	06/83 ->86		AP127201	⌋	⌋	AP127162					⌋
Turbo, GTX			AP127170	⌋	⌋	AP127171					⌋

R 18 Break (134_, 135_)

Diesel			AP127119	⌋	⌋	AP127122					⌋
Diesel	->05/83		AP127161	⌋	⌋	AP127122					⌋
Diesel	06/83 ->86		AP127201	⌋	⌋	AP127122					⌋

R 19 (B/C/L/D53_)

GTX, TXE, TXI, 16v		07/88 ->12/95	AP129108	AP.178108	AP.300030	⌋	AP.177021				⌋	⌋
TXE, TXI, GTX		07/88 ->12/95	AP129108	AP.178108	AP.300030	⌋	AP.177022					⌋
1.9 TD, 16v		1991 ->12/95				⌋						⌋
16v		07/88 ->12/95				⌋	AP.177023					⌋

R 20 (127_)

TL, GTL (R1271)	->ch. 0187000	1976 ->80	AP.127063 *	⌋	⌋	AP129124					⌋
TS, LS (R1272)		1978 ->84	AP.127126 *	⌋	⌋	AP129124					⌋
TL, GTL (R1271)	ch. 0187001 ->	1980 ->84	AP.127126 *	⌋	⌋	AP129124					⌋
TL, GTL (R1270)		1982 ->84									
TD, GTD (R1276)		1980 ->84									
LS, TS (R1277)		1981 ->84									
TX (R1279)		1981 ->84				AP129124					⌋

R 21 (B/L48_) 4x2

1.4 TL, GTL, TS, GTS		03/86 ->06/94	AP129059	AP.178059	AP.300029	⌋	AP.177024				⌋	⌋
1.7 TL, GTL, TS, TSE, RS, GTS												⌋
1.9 SD, GSD												⌋
2.0 TX, GTS, GTX												⌋
1.7 TL		03/86 ->06/89	AP129137 ⇔	AP.178137 ⇔	AP.300029	⌋	AP.177024					⌋
2.0 RX, TX, Ti, GTX, TXE, GTS, TXi			AP129138 ⇔	AP.178138 ⇔								⌋
2.2 RX, GTX, TXE												⌋
2.1 TD, GTD, TBD, TDX												⌋
1.7 TL		07/89 ->06/94	AP129103 ⇔	AP.178103 ⇔	AP.300029	⌋	AP.177024					⌋
2.0 RX, TX, Ti, GTX, TXE, GTS, TXi			AP129102 ⇔	AP.178102 ⇔								⌋
2.2 RX, GTX, TXE												⌋
2.1 TD, GTD, TBD, TDX												⌋
R21 - Taxi							AP.177008					⌋

LipGasTec

Lip 4x4

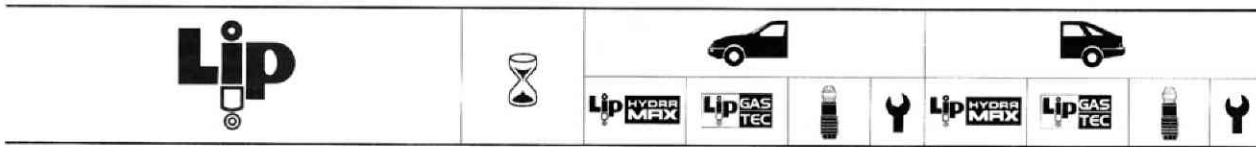

RENAULT

R 21 Nevada (K48_) 🚗

1.6 RX 1.7 TL, TS, GTL, GTS 1.9 D, SD, GSD 2.0 RX	1987 →08/94	AP129059	AP.178059	AP.300029	↑	AP.177008	∞
2.0 RX 2.2 GTX, TXE 2.1 D, TD, GTD 2.2 GTX, TXE	1987 →06/89	AP129137 ⇨ AP129138 ⇩	AP.178137 ⇨ AP.178138 ⇩	AP.300029	↑	AP.177008	∞
2.0 RX 2.2 GTX, TXE 2.1 D, TD, GTD 2.2 GTX, TXE	07/89 →08/94	AP129103 ⇨ AP129102 ⇩	AP.178103 ⇨ AP.178102 ⇩	AP.300029	↑	AP.177008	∞

R 25 (B29_) 🚗

V6, 2.1 TD	04/84 →12/93	AP127296	AP.179296		↓ T	AP.129105	178105	↓
V6, 2.1 TD	04/84 →12/93	AP127296	AP.179296		↓ T	AP.129105	178105	↓

R 30 (127_) 🚗

TS (R1273, R1275)	1975 →84	AP127426 *			↓ T	AP.129124		↓
2.1 TD (R1270)	1982 →84	AP127426 *			↓ T	AP.129124		↓
TX (R1278) →ch. 0022200	1979 →80	AP127426 *			↓ T	AP.129124		↓
TX (R1278) ch. 0022201 →	1980 →84				↓ T	AP.129124		↓

CLIO I (B/C57_) 🚗

1.1, 1.2 1.4 🚗	1990 →07/97	AP129363 ~ AP129364 ~	AP.178363 ~ AP.178364 ~	AP.300094	↑		AP.177025	∞
1.2 1.4	07/97 →09/98	AP129363 ~ AP.178703 ~	AP.178363 ~ AP.178703 ~	AP.300094	↑		AP.177025	∞
1.7, 1.8 16v, Rei, 1.9 D	1990 →07/97	AP129364 ~	AP.178364 ~	AP.300094	↓		AP.177025	∞
1.8 16v	1990 →07/97		AP.178365	AP.300094	↓		AP.177026	∞
1.8 RSi, 1.9 D	07/97 →09/98		AP.178703 ~	AP.300094	↓		AP.177025	∞
1.8 RSi	1993 →07/97		AP.178366	AP.300094	↓		AP.177064	∞
1.8 RSi	07/97 →09/98		AP.178704	AP.300094	↓		AP.177064	∞
Electric	07/97 →09/98		AP.178703 ~	AP.300094	↓			

CLIO

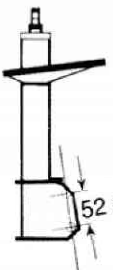

AP.129363/AP.178363

Nº Orig.:

7700 816 045
7700 808 490
7700 823 130
7700 828 680
7700 838 084



AP.129364/ AP.178364

Nº Orig.:

7700 816 046
7700 808 491
7700 823 129
7700 828 681
7700 808 492
7700 823 131
7700 828 682
7700 838 083
7700 838 087



AP.178703

Nº Orig.:

7700 423 726
7700 423 727

LipGasTec

Lip 4x4

**RENAULT****CLIO II (B/C/SB0_)**

1.1, 1.2 8v, 1.2 16v	09/98 → 06/05	AP.129714	AP.178714	AP.300094	↑ AP.127604	AP.179604	LO
1.4, 1.4 16v, 1.6, 1.6 16v, 1.5 DCi, 1.9 D, 1.9 Dti Sport	09/98 → 06/05	AP.129715	AP.178715	AP.300094	↑ AP.127604	AP.179604	LO
1.4 16V, 1.6 16v, 1.9 dTc Sport	09/98 → 06/05		AP.178805	AP.300094	↓	AP.179604	LO
2.0 16v Sport	02/00 → 06/05		AP.178484	AP.300094	↓	AP.179604	LO

CLIO II / SYMBOL / THALIA (TURKEY AND SOUTH AMERICA)

1.4 8v	OE 7700436108	08/00 →	AP.129864	AP.178864	AP.300094	↑ AP.127604	AP.179604	LO
1.4 16v		08/00 →	AP.129715	AP.178715	AP.300094	↑ AP.127604	AP.179604	LO
1.5 dCi	OE 8200221816	08/00 →	AP.129714	AP.178714	AP.300094	↑ AP.127604	AP.179604	LO
	OE 7700428438 7700428602 8200030741 8200299817	08/00 →	AP.129715	AP.178715	AP.300094	↓		

CLIO III (R0_, R1_)

	06/05 →		AP.178985		↑	AP.879048	LO
--	---------	--	-----------	--	---	-----------	----

ESPACE I (J11_)

(J112) 2.0	→ ch. T005812	07/84 → 11/84	AP.127297			↓ T AP.127299	AP.179299	OO
(J112) 2.0	ch. T005813 → T036434	11/84 → 12/87	AP.127298			↓ T AP.127299	AP.179299	OO
(J115) 2.1 TD	→ ch. T020896							
(J117) 2.2	→ ch. T003258							
(S112) 2.0	→ ch. T000620							
(S115) 2.1 TD	→ ch. T000841							
(J112) 2.1 TD	ch. T036435 → ch. K000001 →	01/88 → 12/92	AP.127343			↓ T AP.127344	AP.179344	OO
(J115) 2.1 TD	ch. T020897 →							
(J116) 2.0i	ch. T000001 → ch. K000001 →							
(J117) 2.2	ch. T003259 →							
(S112) 2.0	ch. T000621 →							
(S115) 2.1 TD	ch. T000842 →							

ESPACE II (J/S63_)

3.0 V6		01/91 → 12/96	AP.127761	AP.179761		↓ T AP.127299	AP.179299	OO
3.0 V6		01/91 → 12/96	AP.127761	AP.179761		↓ T AP.127344	AP.179344	OO
		01/91 → 12/96	AP.127761	AP.179761		↓ T		OO

ESPACE / GRAND ESPACE III (JE)

2.0, 2.0 16v	↔ 2.70m	11/96 → 11/02	AP.129716	AP.178716	AP.300030	↓	AP.177104	OO
3.0 V6, 1.9 dTi, 2.2 dT, 2.2 dCi	↔ 2.70m	11/96 → 11/02	AP.129716	AP.178716	AP.300030	↓	AP.177105	OO
2.0, 2.0 16v, 1.9 dTi, 2.2 dT, 2.2 dCi	↔ 2.90m	11/96 → 11/02	AP.129716	AP.178716	AP.300030	↓	AP.179184	OO
3.0 V6	↔ 2.90m	11/96 → 11/02	AP.129716	AP.178716	AP.300030	↓	AP.179184	OO

ESPACE IV (JK0_)

		11/02 →	AP.129848			↓	AP.179757 * AP.179765	OO
--	--	---------	-----------	--	--	---	--------------------------	----

FUEGO (136_)

1.4 TL, GTL (R1360, R1361)		1980 → 85	AP.127170			↓ T AP.127231		LT
1.6, 2.0 GTS, GTX, TS, TX (R1362, R1363)		1982 → 85						
2.1 TD (R1366)		1982 → 85						
1.6 Turbo (R1365)		1984 → 85						

LipGasTec

Lip 4x4

RENAULT
JEEP

CJ5 / CJ6 / CJ7, Renegade, Laredo	1982 -86	AP179772	OO	AP179663	OO
Cherokee (XJ)	1984 -90	AP179773	1-⊕	AP179774	⊕-⊕
YJ Wrangler, Laredo	1987 -95	AP179775	1.O	AP179776	OO

LAGUNA I (B56_)

1.8, 2.0	veh.nº 950421	1994 -96	AP129450 AP.178450 AP.300030	↑	AP.179559	OO
1.8, 2.0 8v (84kW)	veh. nº 950421 → OE 7700830491	1996 -03/01	AP129450 AP.178450 AP.300030	↑	AP.179559	OO
	OE 7700830492		AP129449 AP.178449 AP.300030	↑		
1.6	OE 7700830490	1999 -03/01				
1.8, 2.0 8v (84kW)	veh. nº 950421 →	1996 -03/01	AP129450 AP.178450 AP.300030	↑	AP.179559	OO
2.2 D, 2.2 DT, 3.0 V6		1994 -03/01	AP129674 AP.178674 AP.300030	↑	AP.179559	OO
2.0 16v (103kW)		1996 -03/01	AP.300030			
1.9 DTi, 1.9 dCi		1998 -03/01	AP129450 AP.178450 AP.300030	↑	AP.179559	OO
		1994 -03/01	AP.178674 AP.300030	↑	AP.179559	OO

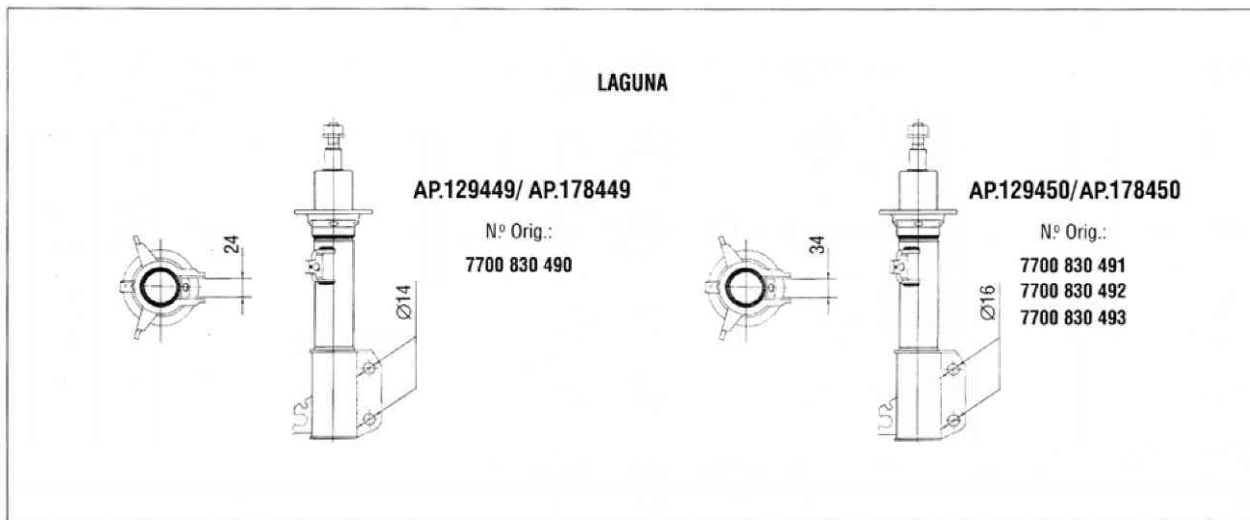
LAGUNA I Grandtour (K56_)

1.8, 2.0	07/95 -03/01	AP129450 AP.178450 AP.300030	↑	AP.179892	OO
1.6, 1.9 DTi, 1.9 dCi	1999 -03/01				
2.2 D, 2.2 DT, 3.0 V6	07/95 -03/01	AP129674 AP.178674 AP.300030	↑	AP.179892	OO
	07/95 -03/01	AP.178674 AP.300030	↑	AP.179892	OO

LAGUNA II (B74_)

1.6 16v	03/01 -	AP129785 AP.178785	↑	AP.127708 AP.179708	OO
1.8 16v	03/01 -	AP129785 AP.178785	↑	AP.127708 AP.179708	OO
1.9 dCi	03/01 -	AP129785 AP.178785	↑	AP.127708 AP.179708	OO
2.0 IDE	03/01 -	AP129785 AP.178785	↑	AP.127708 AP.179708	OO
2.2 dCi	03/01 -	AP129785 AP.178785	↑	AP.127708 AP.179708	OO
2.2 dCi	03/01 -	AP129785 AP.178785	↑	AP.127708 AP.179708	OO
3.0 V6 24v	03/01 -		↑	AP.127708 AP.179708	OO

LipGasTec

Lip 4x4

**RENAULT****LAGUNA II Grandtour (B74_)**

1.6 16v	03/01 →	AP:129785	AP:178785		↑	AP:127708	AP:179708	○○
1.8 16v	03/01 →	AP:129785	AP:178785		↑	AP:127708	AP:179708	○○
1.9 dCi	03/01 →	AP:129785	AP:178785		↑	AP:127708	AP:179708	○○
2.0 IDE	03/01 →	AP:129785	AP:178785		↑	AP:127708	AP:179708	○○
2.2 dCi	03/01 →	AP:129785	AP:178785		↑	AP:127708	AP:179708	○○
2.2 dCi	03/01 →	AP:129785	AP:178785		↑	AP:127708	AP:179708	○○
3.0 V6 24v	03/01 →				↑	AP:127708	AP:179708	○○

MEGANE (BA0_)

2.0 16v, ND	09/95 → 10/02	AP:129636	AP:178636	AP:300030	↑	AP:177086 *	AP:179082 ☺	○○
2.0 16v ND	09/95 → 10/98		AP:178850		↑	AP:177087		○○
2.0 16v ND	10/98 → 10/02		AP:178850		↑	AP:177087		○○
HD	09/95 → 10/02		AP:178447		↑	AP:177086 *	AP:179082 ☺	○○

MEGANE Classic (LA0_)

ND	01/96 → 09/03	AP:129636	AP:178636	AP:300030	↑	AP:177086 *	AP:179082 ☺	○○
HD	01/96 → 09/03		AP:178447		↑	AP:177086 *	AP:179082 ☺	○○

MEGANE Coupé (DA0_)

2.0 16v	09/95 → 09/03	AP:129636	AP:178636	AP:300030	↑	AP:177088		○○
2.0 16v	09/95 → 09/98		AP:178850		↑	AP:177087		○○
2.0 16v	10/98 → 09/03		AP:178850		↑	AP:177087		○○

MEGANE Cabriolet (EA0_)

2.0 16v	02/97 → 09/03	AP:129636	AP:178636	AP:300030	↑	AP:177086 *	AP:179082 ☺	○○
2.0 16v	09/95 → 10/98		AP:178850		↑	AP:177145		○○
2.0 16v	10/98 → 09/03		AP:178850		↑	AP:177145		○○

MEGANE Grandtour (KA0_)

ND	03/99 → 09/03	AP:129636	AP:178636	AP:300030	↑	AP:179884		○○
HD	03/99 → 09/03		AP:178447		↑	AP:179884		○○

MEGANE SCENIC (JA0_) 4x2

1.4, 1.4 16v, 1.6 1.6 1.6 16v	JAOL JAOF	11/96 → 09/03	AP:129636	AP:178636	AP:300030	↑	AP:127476	AP:179476	○○
1.6	JAOF	11/96 → 06/98	AP:129665	AP:178665	AP:300030	↑	AP:127476	AP:179476	○○
1.6	JAOF	06/98 → 09/03	AP:129636	AP:178636	AP:300030	↑	AP:127476	AP:179476	○○
1.9 D	JAOK, JAQY	11/96 → 09/03	AP:129665	AP:178665	AP:300030	↑	AP:127476	AP:179476	○○
1.9 D, 1.9 dTi, 2.0	FAOJ, FAOK, FAOY, JAQJ	11/96 → 06/98	AP:129665	AP:178665	AP:300030	↑	AP:127476	AP:179476	○○
1.9 dTi, 1.9 dCi, 2.0		06/98 → 09/03	AP:129636	AP:178636	AP:300030	↑	AP:127476	AP:179476	○○

MEGANE SCENIC RX4 (JA0_) 4x4

2.0 16v	06/00 →		AP:178636		↑	AP:127476	AP:179476	○○
1.9 dCi, 1.9 dTi	06/00 →		AP:178565 ☺		↑		AP:179819	○○

LipGasTec

Lip 4x4



RENAULT

MEGANE II (BMO_, CMO_)

Renault Sport	11/02 →	AP.129888	AP.178888	↑	AP.177137	⊖
Renault Sport	11/02 →			↑	AP.177148	⊖
Renault Sport	05/04 →					

MEGANE II (LMO/1_)

	09/03 →	AP.129888	AP.178888	↑	AP.177137	⊖
	09/03 →			↑	AP.177148	⊖

MEGANE II Coupé, Cabriolet (EMO/1_)

	09/03 →	AP.129888	AP.178888	↑		⊖
	09/03 →			↑		⊖

MEGANE II GrandTour (KMO/1_)

	09/03 →	AP.129888	AP.178888	↑	AP.177148	⊖
	09/03 →			↑		⊖

MEGANE II Scenic (JM_)

	06/03 →	AP.129989	AP.178989	↑	AP.879033	⊖
	06/03 →			↑		⊖

MEGANE II Grand Scenic

	04/04 →	AP.129989	AP.178989	↑		⊖
	04/04 →			↑		⊖

MODUS (F/JPO_)

	12/04 →		AP.178985	↑	AP.879048	⊖
--	---------	--	-----------	---	-----------	---

SAFRANE I, II (B54_) 4x2

2.0, 2.2, 3.0 V6, 2.1 TD, 2.5 TD X	04/92 → 10/96	AP.129358 →	AP.178358 →	AP.300030	↑	AP.129360	AP.178360	AP.300109	↑
		AP.129359 ←	AP.178359 ←						
2.0, 2.5, 3.0 V6, 2.2 TD X	10/96 → 12/00	AP.129358 →	AP.178358 →	AP.300030	↑	AP.129360	AP.178360	AP.300109	↑
		AP.129359 ←	AP.178359 ←						

TWINGO I

1.1, 1.2	03/93 → 98	AP.129291	AP.178291	AP.300094	↑	AP.127423	AP.179423		⊖
----------	------------	-----------	-----------	-----------	---	-----------	-----------	--	---

TWINGO II

1.2	1998 → 08/00	AP.129733	AP.178733	AP.300094	↑	AP.127423	AP.179423		⊖
-----	--------------	-----------	-----------	-----------	---	-----------	-----------	--	---

TWINGO III

1.2	08/00 →	AP.129798	AP.178798		↑	AP.127886	AP.179886		⊖
-----	---------	-----------	-----------	--	---	-----------	-----------	--	---

VEL SATIS (BJD)

	11/02 →	AP.129849			↑		AP.179756		⊖
--	---------	-----------	--	--	---	--	-----------	--	---

LipGasTec Lip 4x4



RENAULT COMMERCIAL

SUPER 5 / EXPRESS (F40_) 🚚

Utilitaire, Express, Extra, Rapid	776kg	1985 → 96	AP.129066	AP.300034	↑	AP.177004	∞
Utilitaire, Express, Extra, Rapid	776kg	01/96 → 10/96	AP.129582	AP.300034	↑	AP.177004	∞
Utilitaire, Express, Extra, Rapid	776kg	10/96 →	AP.129651		↑	AP.177004	∞
Utilitaire, Express, Extra, Rapid	775kg	1991 → 95	AP.129134		↑	AP.177048	∞
Utilitaire, Express, Extra, Rapid	775kg	01/96 → 10/96	AP.129584		↑	AP.177048	∞
Utilitaire, Express, Extra, Rapid	775kg	10/96 →	AP.129651		↑	AP.177048	∞

KANGOO (KCO_) 🚚

580kg, Pampa	OE 7700311596 OE 7700314021	01/98 →	AP.129691	AP.300094	↑	AP.177103	∞
750kg, Pampa	OE 7700311597 OE 7700314022	01/98 →	AP.129691	AP.300094	↑	AP.179554	∞
Pampa	OE 7700311598 OE 7700314023	01/98 →				AP.179554	∞
4x4	OE 8200041472	01/98 →				AP.179579	∞

MASTER Q Series 🚚

		→ 1998	AP.127359	AP.300083	↓	AP.177147	∞
		07/98 →					

MASTER R Series 🚚

		05/80 → 02/89	AP.127359	AP.300083	↓		
		02/89 → 97		AP.179766 AP.300083	↓		

MASTER R Series 🚚

		05/80 → 97				AP.127181	LT
RL 7							
RC 7							
RCA		05/80 → 97				AP.179769	LT
RC 9						AP.177147	∞
RD 9							
RL 9							
RH 9		05/80 → 97				AP.127181	LT
RJ 9		05/80 → 97					

MASTER (FD, ED, HD, UD)

(FD)		07/98 →	AP.127606			∞	AP.179225	∞
(FD)		07/98 →	AP.127606			∞	AP.179291	∞
(ED, HD, UD)		07/98 →	AP.127606			∞	AP.179224	∞
(ED, HD, UD)		07/98 →	AP.127606			∞	AP.179290	∞

TRAFIC P Series 4x2 RWD 🚚

P3	→ veh.n° 0003373	1981 → 82	AP.129204 ⇔	AP.178204 ⇔	↑		∞
P5	→ veh.n° 0000224	1981 → 82	AP.129205 ⇔	AP.178205 ⇔			
P64	→ veh.n° 0000105	1981 → 82					
P3	veh.n° 0003374 →	1982 → 02/89	AP.129204 ⇔	AP.178204 ⇔	↑	AP.127373	∞
P5	veh.n° 0000225 →	1982 → 85	AP.129205 ⇔	AP.178205 ⇔			
P64	veh.n° 0000106 →	1982 → 02/89					
'8		1982 → 86					
P6C		1981 → 86	AP.129204 ⇔	AP.178204 ⇔	↑	AP.127373	∞
PA		1981 → 86	AP.129205 ⇔	AP.178205 ⇔			
PC		1984 →					

LipGasTec

Lip 4x4



RENAULT COMMERCIAL

TRAFIC T Series 4x2

T1 exc.		1981 ·02/89	AP129204 ⇔ AP.178204 ⇔	↑ AP:127131	LO
T1		03/89 ·03/01	AP129205 ⇔ AP.178205 ⇔		
T2		1986 ·03/01			
T3		1981 ·03/01			
T4 exc. , T42.,T46.		1981 ·02/89			
T42	→ch. 0025720	1981 ·12/82			
T4		03/89 ·03/01			
T5B		03/89 ·03/01			
T46	ch. 0025721 ·	01/83 ·02/89	AP129204 ⇔ AP.178204 ⇔	↑ AP:127131	LO
			AP129205 ⇔ AP.178205 ⇔		
T1		1981 ·02/89	AP129204 ⇔ AP.178204 ⇔	↑ AP:127346	LO
T4		1981 ·02/89	AP129205 ⇔ AP.178205 ⇔		
T5		1981 ·02/89			
T53		03/89 ·03/01			
T6		1983 ·86			
T7		1986 ·03/01			
T9		1983 ·89			
TA		1981 ·86			
TB		1986 ·03/01			
TE		03/89 ·03/01			

TRAFIC V Series 4x4

V2		1987 ·88	AP129204 ⇔ AP.178204 ⇔	↑ AP:127373	OO
V3		03/89 ·03/01	AP129205 ⇔ AP.178205 ⇔		
V4		1987 ·03/01			
V5		1985 ·03/01			
V9		1985 ·88			

TRAFIC (JL, FL)

		03/01 ·	AP:178841	↑ AP:127810 * AP:179810	OO
--	--	---------	-----------	-------------------------	----